

WMB

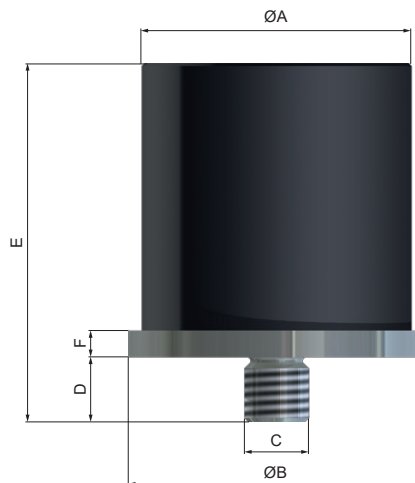

Material	PUR, micro-cellular Base: steel, zinc plated
Load	2 - 225 Nm
Temperature	-30°C - max. +80°C (-22°F - max. +176°F)
Impcat speed	max. 5 m/s
Long life time	Resistant to oil, grease, ozone, UV radiation, weathering and splash water
Applications	End stop of machines, Crane systems



DIMENSIONS

	max. Deflection	Energy absorption		ØA	ØB	C	D	E	F
	mm (inch)	Constant load Nm (in lbs)	Emergency Nm (in lbs)						
WMB-10-10-6	8 (0.31)	2 (18)	3 (27)	10 (0.39)	11 (0.43)	M3	3 (0.12)	15,5 (0.61)	3 (0.12)
WMB-20-20-6	16 (0.63)	10 (89)	16 (142)	20 (0.79)	23 (0.91)	M6	6 (0.24)	28,5 (1.12)	3 (0.12)
WMB-20-20-6-M5	16 (0.63)	10 (89)	16 (142)	20 (0.79)	23 (0.91)	M5	5 (0.2)	27,5 (1.08)	3 (0.12)
WMB-30-30-6	24 (0.94)	45 (398)	85 (752)	30 (1.18)	33 (1.3)	M6	6 (0.24)	38,5 (1.52)	3 (0.12)
WMB-40-40-6	32 (1.26)	85 (752)	135 (1195)	40 (1.57)	45 (1.77)	M8	8 (0.31)	50,5 (1.99)	3 (0.12)
WMB-50-50-6	40 (1.57)	170 (1505)	225 (1991)	50 (1.97)	55 (2.17)	M12	12 (0.47)	66,5 (2.62)	5 (0.2)

INSTALLATION



The entire diameter of the base must lie flat on the counterpart.

Recommendation: secure screw-in thread with a screw-locking adhesive.

